

| REVISIONS |             |      |          |
|-----------|-------------|------|----------|
| REV.      | DESCRIPTION | DATE | APPROVED |
|           |             |      |          |
|           |             |      |          |
|           |             |      |          |

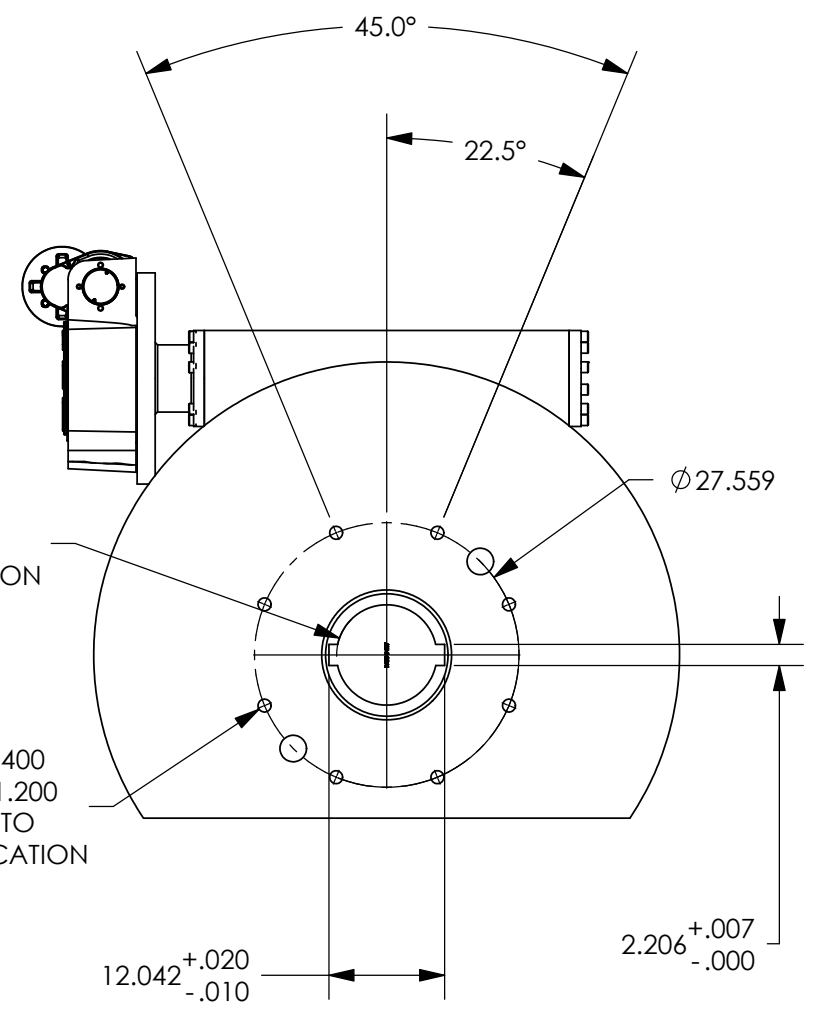
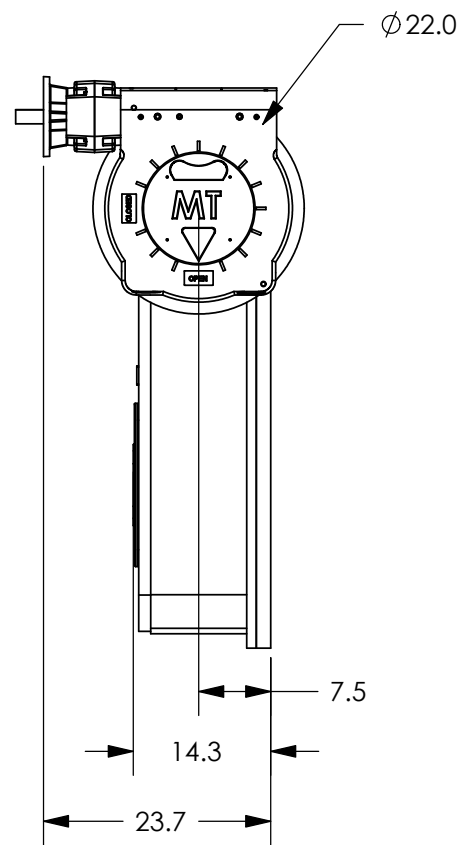
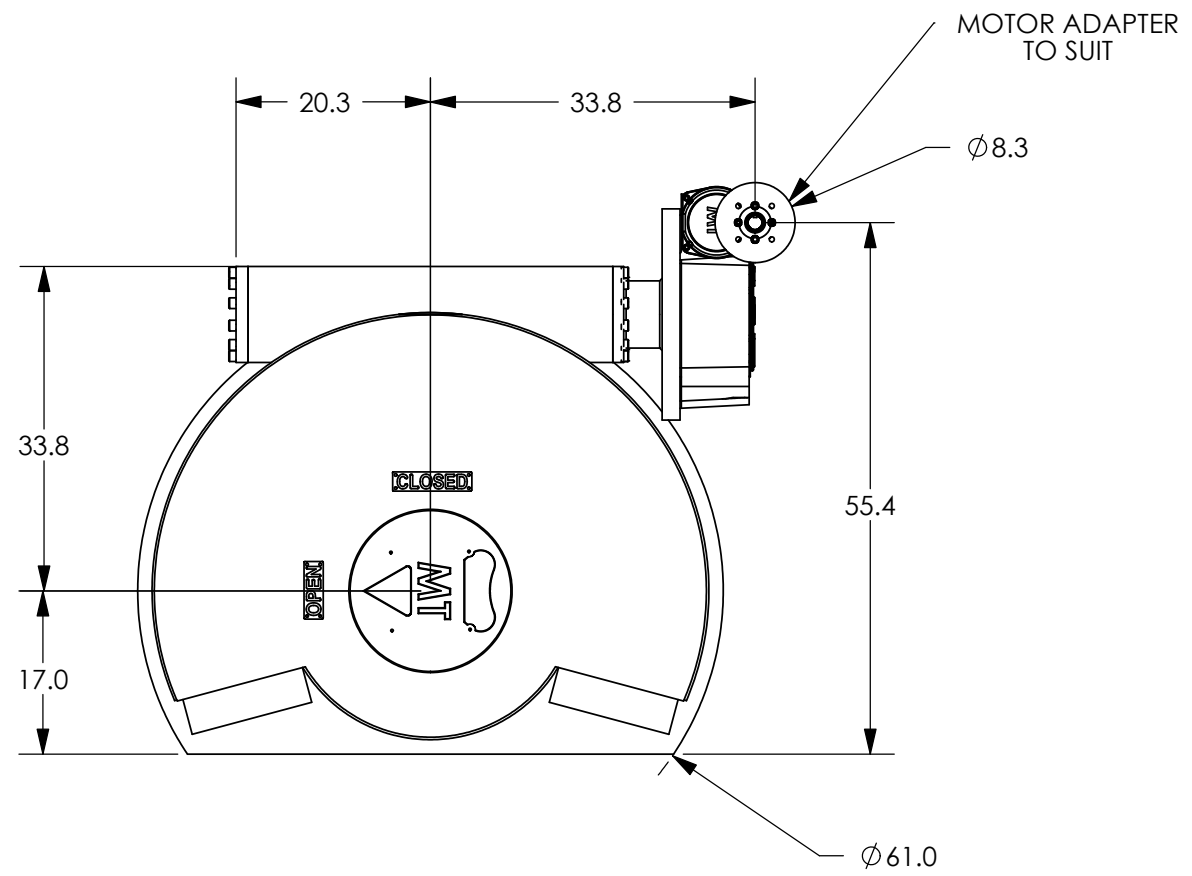

- NOTES:
- FINAL RATIO: 2376.6 : 1  
BASE RATIO: 42.25 : 1, WORM GEAR REDUCER RATIO: 18.75 : 1, BASE SPUR RATIO: 3 : 1
  - MAX BORE & KEY:  $\phi 10"$  W/2 1/2" X 2" KEY
  - MAX STEM ENGAGEMENT: 15 3/4"
  - APPROXIMATE WEIGHT: 4785 LBS
  - UNIT IS SHOWN IN THE "OPEN" POSITION

**PROPRIETARY AND CONFIDENTIAL**  
THE INFORMATION CONTAINED IN THIS DRAWING IS THE SOLE PROPERTY OF MAX TORQUE. ANY REPRODUCTION IN PART OR AS A WHOLE WITHOUT THE WRITTEN PERMISSION OF MAX TORQUE IS PROHIBITED.

|                                |       |
|--------------------------------|-------|
| UNLESS OTHERWISE SPECIFIED:    |       |
| DIMENSIONS ARE IN INCHES       |       |
| TOLERANCES:                    |       |
| FRACTIONAL $\pm 1/32$          |       |
| ANGULAR: MACH $\pm 1/2$        |       |
| BEND $\pm 1/2$                 |       |
| TWO PLACE DECIMAL $\pm .02$    |       |
| THREE PLACE DECIMAL $\pm .005$ |       |
| MATERIAL:                      | N/A   |
| FINISH:                        | PAINT |
| DO NOT SCALE DRAWING           |       |

|           |         |
|-----------|---------|
| NAME      | DATE    |
| JM        | 7/27/06 |
| DRAWN     |         |
| CHECKED   |         |
| ENG APPR. |         |
| MFG APPR. |         |
| Q.A.      |         |
| COMMENTS: |         |



TITLE: MW5,WGR,BS3,&MTR ADAPT  
3000K TO 3600K IN-LBS

|          |          |      |
|----------|----------|------|
| SIZE     | DWG. NO. | REV. |
| <b>B</b> | 300128   |      |

SCALE: 1:20 WT: 4785 lbs SHEET 1 OF 1

Thursday, July 27, 2006 5:19:34 PM