



The Best Valve Actuation Products in the World

TEMPERATURE COMPENSATION

PURPOSE ENGINEERED, QUALITY MANUFACTURED, PERFORMANCE TESTED

- **Sandwich design ideal for new projects or retrofits**
- **Proven Belleville spring design**
- **Unique “floating” thrust bearing stem nut cartridge**
- **High quality thrust bearings for robust performance**
- **Stem sizes to 10” +**
- **Growth to .250” +**
- **Single or double acting**

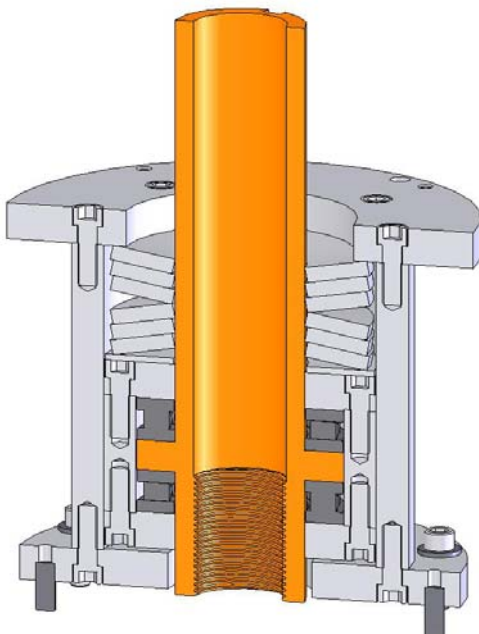

- ⇒ Extend valve life
- ⇒ Reduce gear wear and damage
- ⇒ Quick delivery
- ⇒ Application engineered

www.maxtorquegears.com

Also offering engineered solutions and novel actuation packages including declutch overrides and thermal isolators and risers

PO Box 534
81 Central Ave.
Limerick, ME 04048

Houston: 281-257-9666
Phone: 207-793-2289
Fax: 207-793-2014
E-mail: pat@maxtorquegears.com