



The Best Valve Actuation Products in the World

## HIGH TORQUE, HIGH THRUST RISING STEM APPLICATIONS

### PURPOSE ENGINEERED, QUALITY MANUFACTURED, PERFORMANCE TESTED

#### High Thrust Spurs, a Critical High Speed Rising Stem Solution:

- Highly efficient spur gear drive train utilizing heat treated steel
- Highest quality thrust bearings
- From 5,000 to 300,000 + ft/lbs torque
- 2 MM + lbs thrust
- Manual or motorized applications
- Available “Double Idler” gearset allows for exceptionally high torque while maintaining a low profile

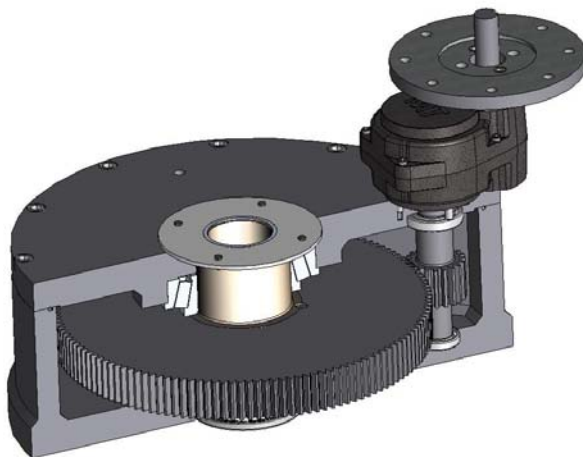

- **Stronger and cost effective compared to large bevels**
- **Quick delivery**
- **Application engineered**
- **Easily accommodates mounting adaptation and stem covers**
- **High temperature packages available.**

**Also offering engineered solutions and novel actuation packages including rising stem overrides and temperature compensation**

[www.maxtorquegears.com](http://www.maxtorquegears.com)

34 Business Park Road  
Limerick, ME 04048

Phone: 207-793-2289  
Fax: 207-793-2286  
E-mail: [pat@maxtorquegears.com](mailto:pat@maxtorquegears.com)